

Plane of foundation
Fundamentplan
Plan de fondation
Schema fondazioni

STANDARD DS600

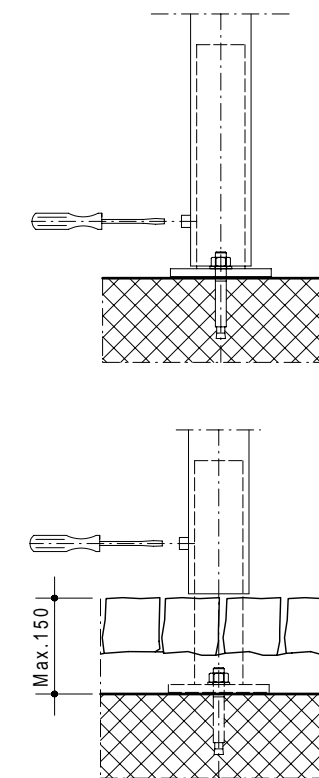
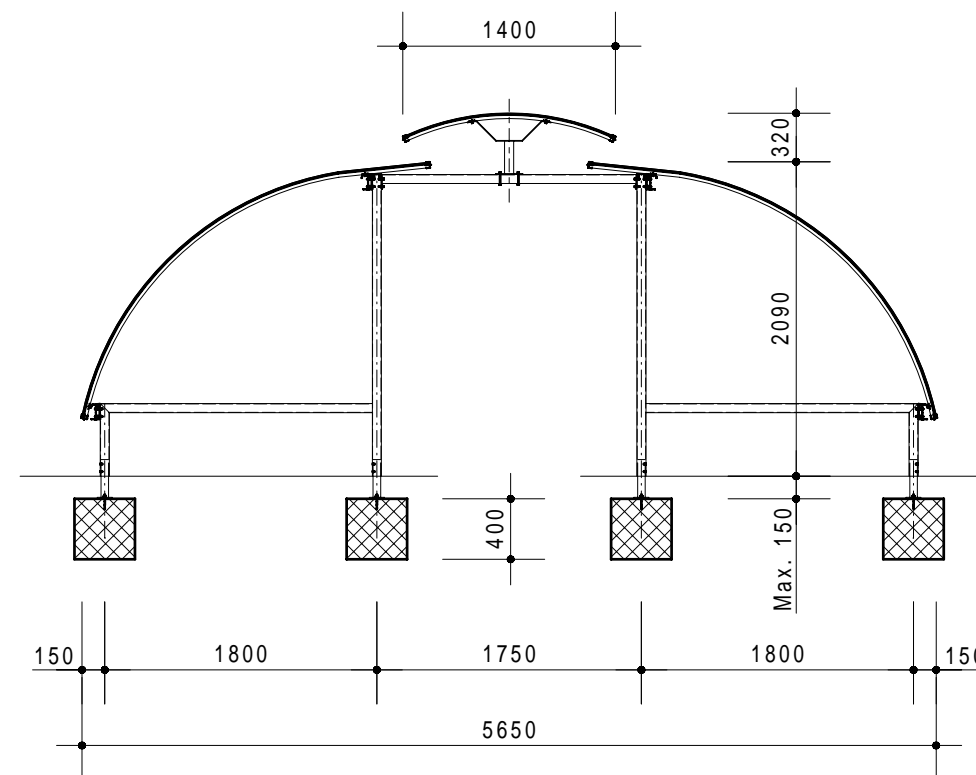

ON REQUEST - AUS ANFRAGE - SUR DEMANDE - SU RICHIESTA

Wall side - Seitenwände
Finition laterales - Pareti laterali

Holder - Velohalter
Support - Supporti

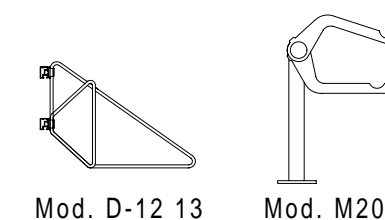
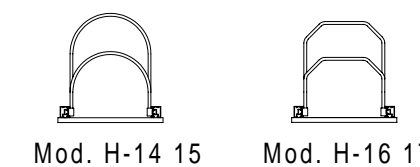
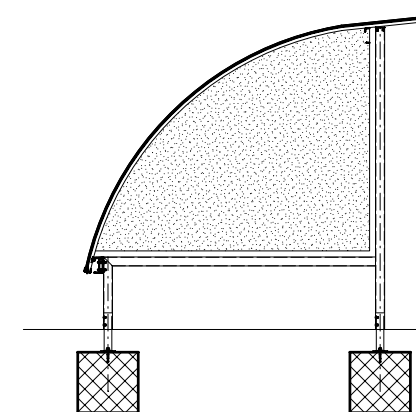

Trattamento: Ferro zincato a bagno		Alu ossidato naturale	N° pezzi
Committente:			N° ordine
Modello: STANDARD DS	Materiale: FERRO - STAHL		Data: Sett. 05
Descrizione COPERTURA CICLI E MOTOCICLI " STANDARD DS "			Disegnato: GB
ÜBERDACHUNGEN FAHRRADRÄDER UND MOTORRÄDER " Standard DS "			
N° dis. / Articolo		STANDARD DS600	

KERNSTUDER
TRENnwÄNDE + TORE

Weberütistrasse 9
8833 Samstagern
T 044 783 22 44 F 044 783 22 43
info@kern-studer.ch
www.kern-studer.ch